

Maße / Dimensions Schieber Serie AT 200 mit Zylinder Knife gate valve series AT 200 with pneumatic cylinder DN 50 - DN 300

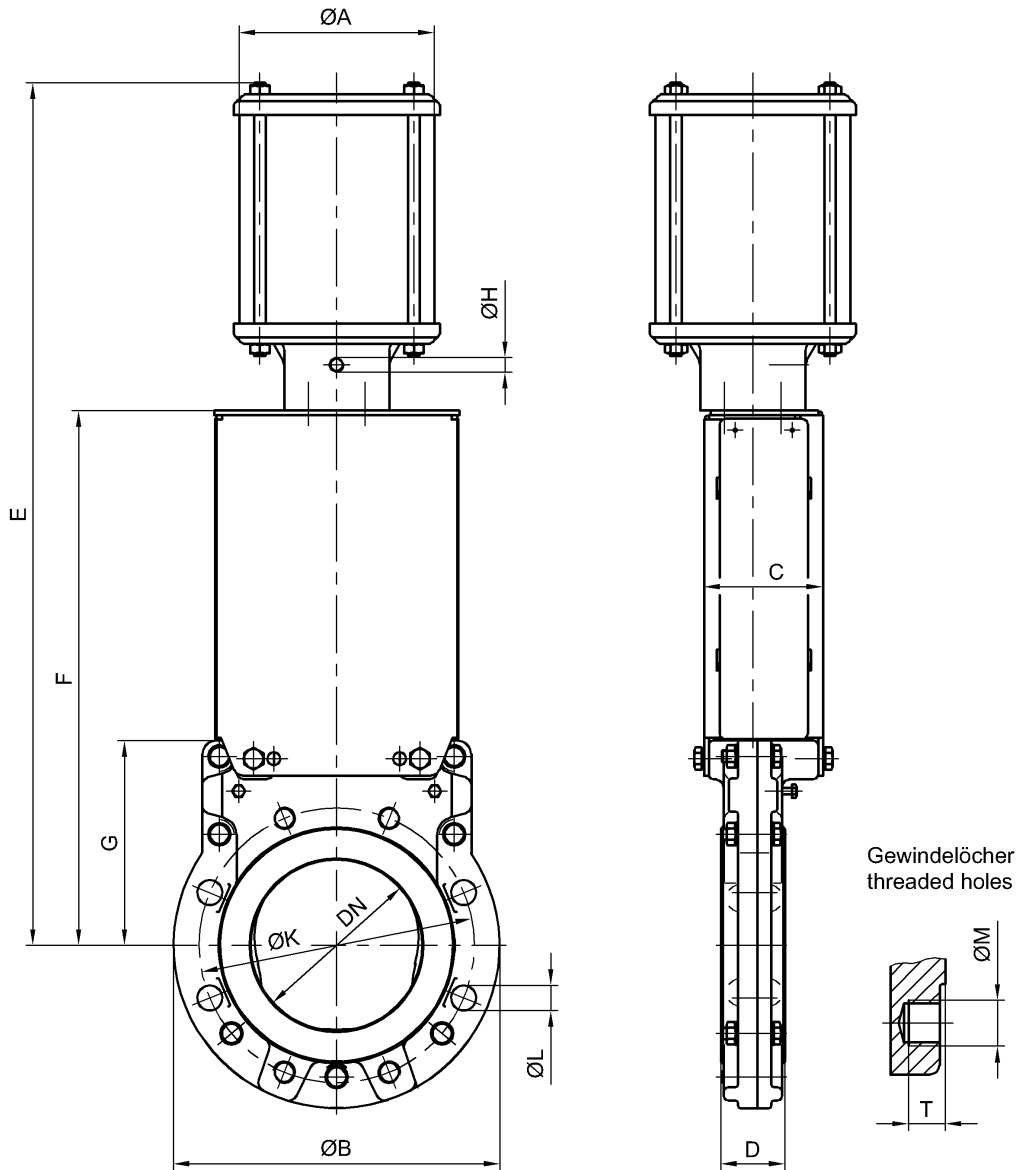

DN	NPS	P _D	ØA	ØB	C	D	E	F	G	ØH	ØK	ØL	ØM	T	kg
50	2"	10	80	165	91	43	407	252	110	R1/4"	125	-	4xM16	16	12
65	2 1/2"	8	80	185	91	46	427	257	115	R1/4"	145	-	4xM16	18	14
80	3"	5	80	200	91	46	463	278	139	R1/4"	160	4xØ18	4xM16	13	16
100	4"	5	100	220	96	52	561	349	152	R1/4"	180	4xØ18	4xM16	16	20
125	5"	4	100	250	96	56	595	358	160	R1/4"	210	4xØ18	4xM16	18	23
150	6"	6	160	285	104	56	753	467	179	R1/4"	240	4xØ22	4xM20	16	36
200	8"	6	200	340	104	60	857	497	209	R1/4"	295	4xØ22	4xM20	18	50
250	10"	7	250	395	141	68	1100	660	257	R1/4"	350	6xØ22	6xM20	21	88
300	12"	5	250	445	141	78	1190	700	297	R1/4"	400	6xØ22	6xM20	21	110

P_D [bar] = max. Differenzdruck bei Betätigung / max. differential pressure during operation

Steuerdruck für Zylinder / air pressure for cylinder: 6 bar

Max. Betriebsdruck / max. working pressure: 10 bar

Änderungen vorbehalten
 subject to changes